

PD.EN0001 - 15" / 18" / 21" | BASS REFLEX ENCLOSURES

ENCLOSURE CONSTRUCTION

MATERIAL

We recommend the use of a multi-layer, void free, exterior grade birch ply. Thickness should be at least 18mm (3/4") and 24mm (1") for larger enclosures. Other kinds of wood (e.g. Pine, blackboard and hardwoods) may be used for construction, but the resulting strength and acoustic properties will be affected. As a cheaper option Medium Density Fibreboard (MDF) or flooring-grade chipboard can be used where the cabinet is to be permanently installed in a dry situation.

METHOD / TECHNIQUE

We recommend lapped joints, however simple butt joints are adequate, both types of joint should be airtight. All joints should be bonded with a sufficient bead of glue to ensure good adhesion (PVA or PU glue is suitable) and screwed at 200mm (8") centres with 4.2mm or 4.8mm (No.8 or 10 gauge) x 60mm (2 3/8") screws. A high quality wood screw should be used. Make sure there's a clearance hole in the wood that the screw head bears down on, so the pieces of wood are pulled fully together. To curtail major resonances (e.g. spurious buzzing noises), major panels should be stiffened with battens; off-cuts are often used, however we recommend purpose made braces for optimum performance. These should be glued and screwed into place. The arrangement must be consistent (between like cabinets) to ensure performance remains the same. To reduce panel resonance further a larger number of smaller braces can be used.

In the past, cabinets were constructed with removable back panels. Modern practice is to mount the drive units from the front. This allows direct access for maintenance and inspection of the drivers, sockets and crossovers. A removable back panel isn't required, which helps ensure the airtightness of the enclosure.

HOLE CUTTING

Fixing holes to mount the loudspeaker may be defined using the holes in the driver frame. The loudspeaker is then mounted using bolts and 'T' nuts supplied. All other holes for connectors, handles, etc should be cut before any other parts are mounted.

PASSIVE CROSSOVERS

Crossover networks should be mounted for ease of access, but at the same time they should be kept away from the immediate vicinity of the driver(s)' magnets. Crossover PCBs need to be firmly secured; buzzing or rattling will impair sound quality. If a crossover breaks loose in transit, the crossover and/or drivers may be damaged. Self-tapping screws provide the suitable fixing, taking care to ensure a tight fit. Screw cups spread out the pressure exerted on the PCB, reducing the chances of damage if the cabinet is dropped from a height. Rubber grommets can be used to space the crossover PCB off the cabinet wall, and can protect the PCB/components it from the resulting shock.

CONNECTORS

Some connectors leak air. Be sure to check the connectors are suitable for the application intended.

INTERNAL WIRING

Wiring should be clearly coded so correct polarity is visible. We recommend red and black for hot (+ve) and cold (-ve) respectively. When the enclosure is first tested, use a battery or polarity ('phase')-checker set to ensure that the driver(s)' cones move forwards (outwards) when the hot (+ve) input terminal is driven positive.

ACOUSTIC TREATMENT

The inside of the enclosure should be aged (lightly filled) with an absorptive material, to deaden internal reflections. Recommended materials are BAF or a similar cushion filler. For best results staple the wadding to the cabinet walls. The amount of wadding will affect the acoustic performance of the enclosure and is best adjusted to give the desired response.

There are two port sizes given in the table for each enclosure; the shorter port reduces the bass extension of the cabinet, while maintaining sensitivity, the longer port increases bass extension at the sacrifice of sensitivity.

The response of the cabinets can be tailored to suit your own requirements by adjusting both the density/amount of wadding and altering the port sizes within the dimensions given.

DRIVE UNITS

Before mounting the drive units, the internal wing, connectors (and passive crossovers where applicable) should be fitted. Make sure the cabinet interior is clear and free from swarf and waste. Drive units are fitted with a foam sealing strip to provide airtight conditions when bolted down. Make sure this is in place and intact before fixing the driver. The driver's fixing bolts should be tightened in stages, in a diagonal sequence to avoid possible deformation of the chassis or baffle.

Further information about our drive units can be found at <http://www.precision-devices.com>

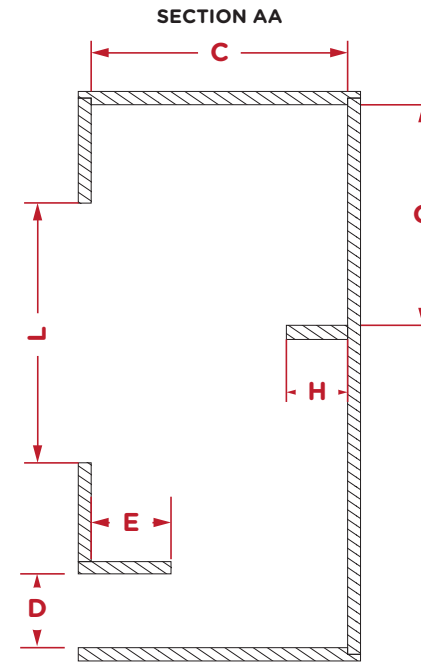
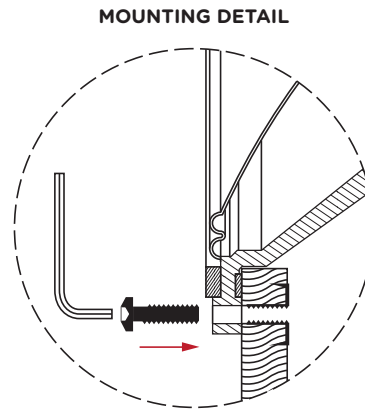
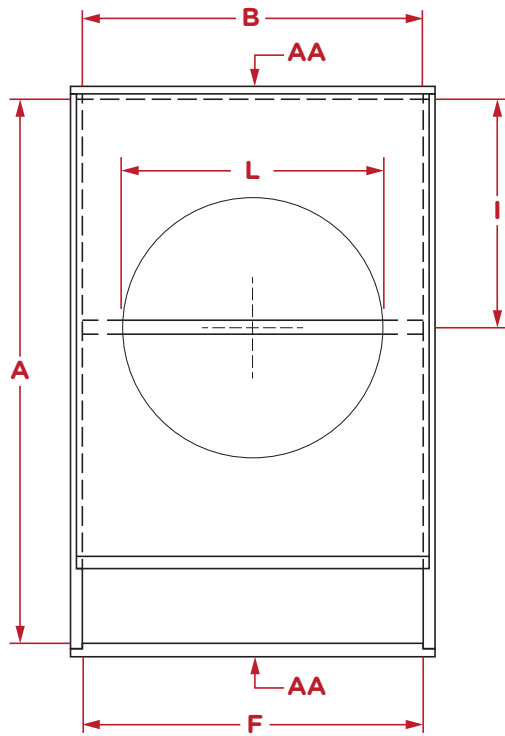

DIMENSION KEY	SPEAKER MODEL		
	15" DRIVERS	18" DRIVERS	21" DRIVERS
A	743 mm / 29.25"	865 mm / 34"	988 mm / 29.87"
B	465 mm / 18.30"	544 mm / 21.41"	615 mm / 24.21"
C	357 mm / 14.05"	410 mm / 16.14"	467 mm / 18.38"
D	100 mm / 3.93"	113 mm / 4.44"	136 mm / 5.35"
E	127 mm / 5.00"	158 mm / 6.22"	122 mm / 4.80"
E.1	250 mm / 9.84"	300 mm / 11.81"	350 mm / 13.77"
F	465 mm / 18.30"	544 mm / 21.41"	558 mm / 21.96"
F.1	400 mm / 15.74"	450 mm / 17.71"	500 mm / 19.68"
G	310 mm / 12.20"	390 mm / 15.35"	440 mm / 17.32"
H	100 mm / 3.93"	100 mm / 3.93"	120 mm / 4.72"
I	310 mm / 12.20"	364 mm / 14.33"	415 mm / 16.33"
J	395 mm / 15.55"	455 mm / 17.91"	526 mm / 20.70"
K	370 mm / 14.56"	N/A	N/A
L	357 mm / 14.05"	419 mm / 16.49"	499 mm / 19.64"

